



# SHURFLO REVOLUTION™ 4008 SERIES PUMP

## RV FRESH WATER PUMP – PRODUCT TECHNICAL DATA SHEET

OEM: 4008-101-A65  
 AFTERMARKET: 4008-101-E65



### APPLICATION:

Multi-fixture RV fresh water pump installation.  
 This pump may be used for general fresh water transfer

### PUMP DESIGN:

Type: 4 Chamber Diaphragm pump  
 Check Valve: (1-way operation) Prevents Reverse Flow  
 Ports: 1/2" -14 NPSM-Male  
 Liquid: 130°F [54°C] Max  
 Dry-Prime: 6 feet [1.82 M]  
 Run Dry: Yes  
 Inlet Pressure: 30 PSI Max. [2.06 Bar]

### ELECTRICAL:

Motor: 12V DC Permanent Magnet, Intermittent Duty  
 Protection: Thermal Overload, Automatic Restart  
 Leads: 16 AWG, 10" [25 cm] Red +, 13" [33 cm] Black  
 Fuse: 10 Amp Recommended  
 Control: Shut-Off 55 PSI [3.8 Bar] ± 2 PSI [0.13 Bar]  
 Re-start 40 PSI [2.8 Bar] ± 2 PSI [0.13 Bar]  
 Maximum By-Pass 62 PSI [4.2 Bar] ± 2 PSI [0.13 Bar]

### MATERIALS OF CONSTRUCTION:

Housings: Polypro  
 Valves/Seals: EPDM  
 Diaphragm: Santoprene  
 Hardware: Stainless Steel and Zinc Plated Steel

### AGENCY APPROVALS:

CSA

### SHIPPING INFORMATION:

Approx. Net Weight: 5 lbs. [2.3 Kg] ea.  
 Carton Qty.: 12  
 Approx. Carton Weight: 60 lbs. [27 Kg]  
 Approx. Carton Size: 24"L X 18"W X 11"H [61cm x 46cm x 28cm]

### REPAIR KITS

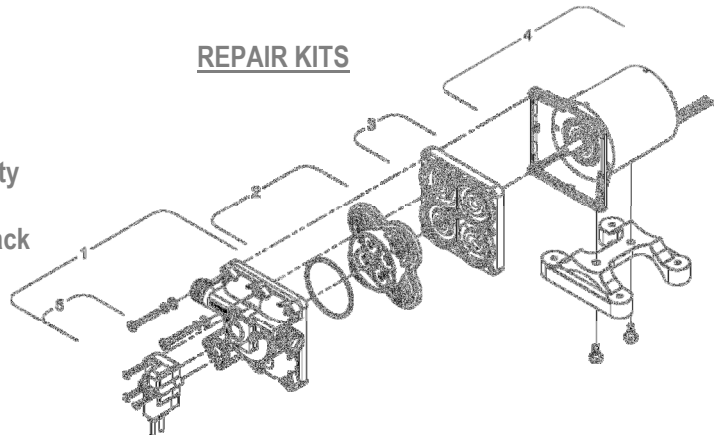

Number	Description	Part Number
*1,5	Upper Assy.	94-800-00
2	Valve Assy.	94-800-01
3	Drive Assy.	94-800-02
4	Motor	94-11-302-00
Not Shown	Check Valve	94-800-03
*1,2,3,5	Pump Head	94-800-04
*5	Pressure Sw.	94-800-05

\*With preset switch and by-pass adjustment

**RELATED DOCUMENTS:**

Catalog: MS-030-138  
 App Guide Sheet : MS-020-005  
 Installation Manual: 911-1008  
 Aftermarket Warranty: 911-1044

**TYPICAL PERFORMANCE AT 12V**

PRESSURE		FLOW		CURRENT
BAR	PSI	GPM	LPM	AMPS
0	0	3.0	11.3	2.2
0.7	10	2.2	8.3	3.3
1.4	20	1.8	6.8	4.3
2.1	30	1.5	5.7	5.1
2.8	40	1.2	4.5	6.0
3.4	50	0.5	1.9	6.8
4.1	60	0	0	6.6

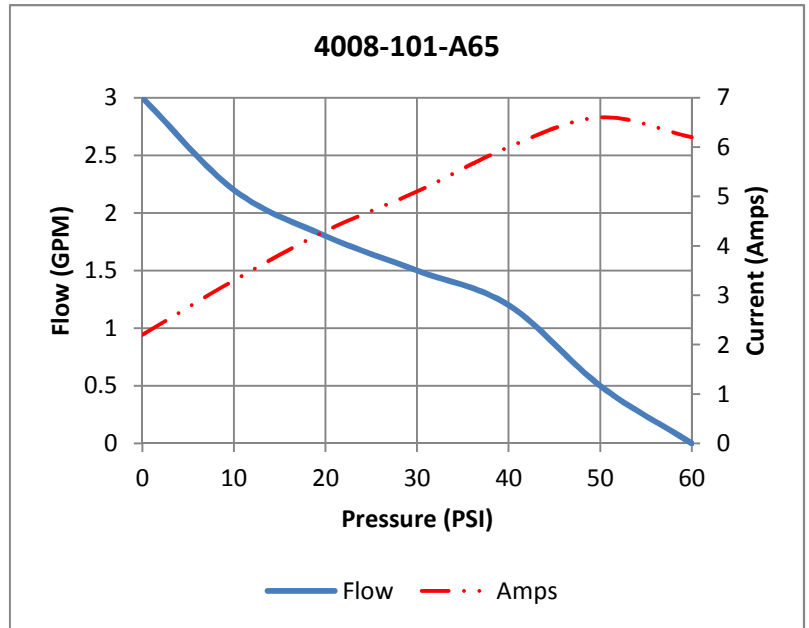

**DIMENSIONS [mm]**

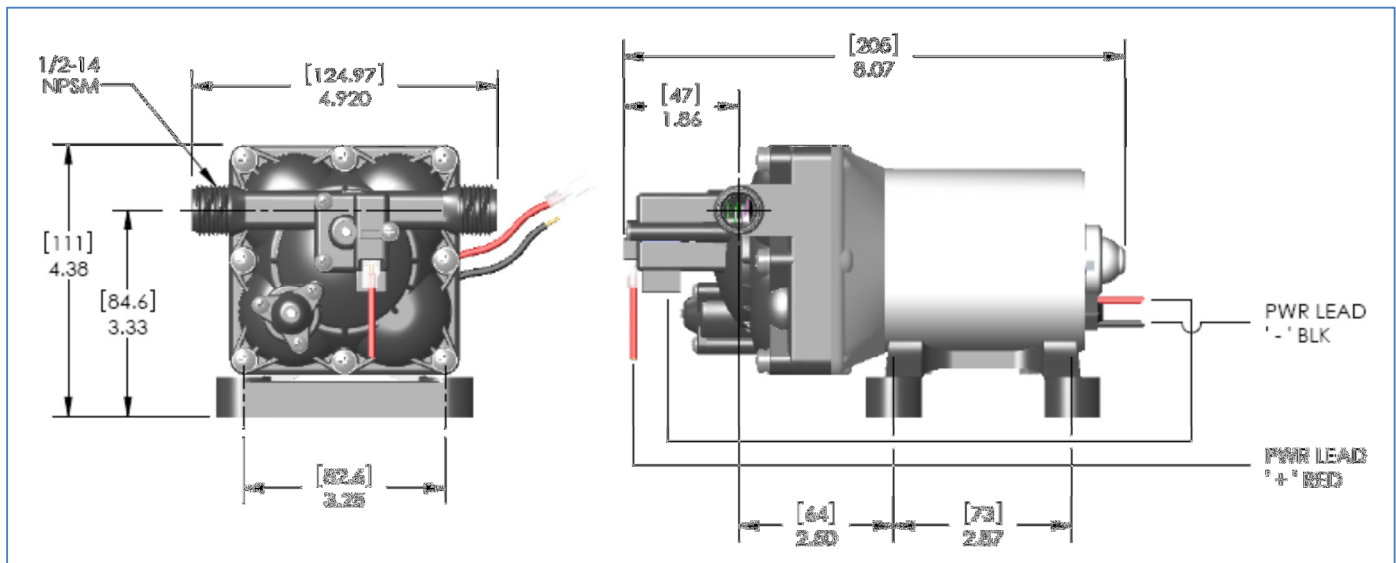

**WATER PURIFICATION**

3545 Harbor Gateway South, Suite 103, Costa Mesa, CA 92626, (800) 854-3218 www.SHURFLO.com

All Pentair trademarks and logos are owned by Pentair, Inc. All other brand or product names are trademarks or registered marks of their respective owners. Because we are continuously improving our products and services, Pentair reserves the right to change specifications without prior notice. Pentair is an equal opportunity employer.